

Standard equipments

Equipments and performance

- Stage V Cummins engine QSF 3.8
- Steel crawlers (500mm track plates)
- Boom 4600mm & Arm: 2500mm
- 1st Auxiliary hydraulic circuit line to arm end (2 pipes)
- 2nd Auxiliary hydraulic circuit line to arm end (2 pipes)
- Hydraulic quick hitch line to arm end (2 pipes)
- Oil return pipe (1pipe)
- Dual proportional joysticks
- two LED work lights under the boom
- one LED working light on right side of upcarriage
- Beacon light with magnetic base
- Radio with usb portal
- Air-conditioning
- Boom safety valve
- Electric refuelling pump
- Arm safety valve
- Travelling alarm
- Auto-shift travelling
- Safety handrails for engine inspections
- Rear- and right hand side camera
- Battery cut-off switch (plastic)
- TOPS / FOPS / ROPS cabin
- Premium seat with air suspension
- Touchable monitor touch screen (user data + incident warning)
- Grease gun and tool box
- Operator's manual
- One standard bucket 940mm, 610L
- Aux1 P1 & P2 confluence
- Dozer blade



Dimensions

- A** 8270mm
- B** 2860mm
- C** 2490mm
- D** 940mm
- E** 410mm

- F** 2515mm
- G** 2915mm
- H** 3650mm
- I** 1990mm

- J** 2490mm
- K** 500mm
- L** 2860mm
- N** 2490mm

- a** 8600mm
- b** 6145mm
- c** 5530mm
- d** 5320mm
- e** 4930mm

- f** 8330mm
- g** 8185mm
- h** 2575mm
- i** 487mm
- j** 650mm

WORKING RANGE

DIMENSIONS

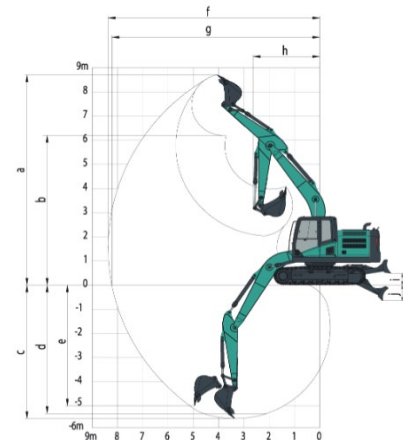
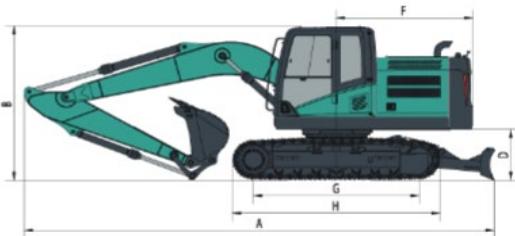

Operating weight: 14700 kg
 Overall dimensions (L x W x H): 8270 x 2490 x 2860mm

The above parameters may be different due to product updating